

EN

MANURHIN K'MX

PRODUCTION PROGRAM

 TAJMAC – ZPS 

 MANURHIN K'MX®

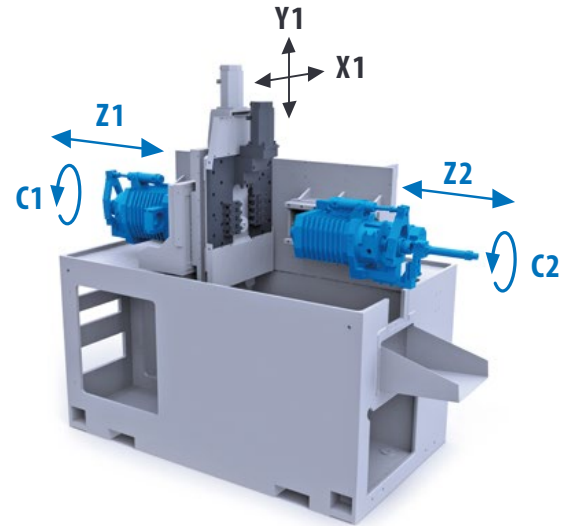
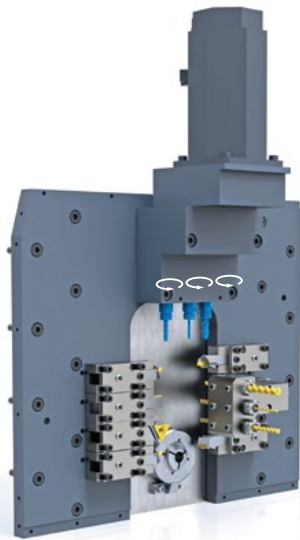

THE MANURHIN K'MX 413 is dedicated to run small parts from $\varnothing 3$ (2)–16 mm (over $\varnothing 13$ mm, preparation of bars is necessary in standard, as an option it can be used with full $\varnothing 16$ mm bars without preparation). Subspindle, powered tools are included in the basic machine as well as the bar loader. With 2 electrospindles, 3 powered tools, C-axis, and up to 12 fixed tools, the K'MX 413 is also able to run complex parts. With this machine, we want to offer an economical, reliable and easy solution. Four linear axes (X1, Y1, Z1, Z2), two rotary axes (C1, C2).

Specifications

Max. diameter of bar stock \varnothing	13 (16)
Spindle bore \varnothing	18 (19)
Spindle power kW 100%/30min. - main	3,7/5,5
Spindle power kW 100%/30min. - sub	2,2/3,7
Spindle max. speed rpm - main	12 000
Spindle max. speed rpm - sub	12 000
Spindle stroke mm	130
Number of CNC axes	4+2
Programming channels	2
Tools in cut at the same time max	2
Live tools power kW	1

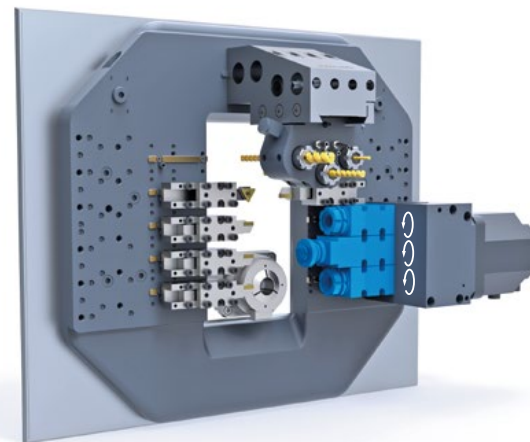
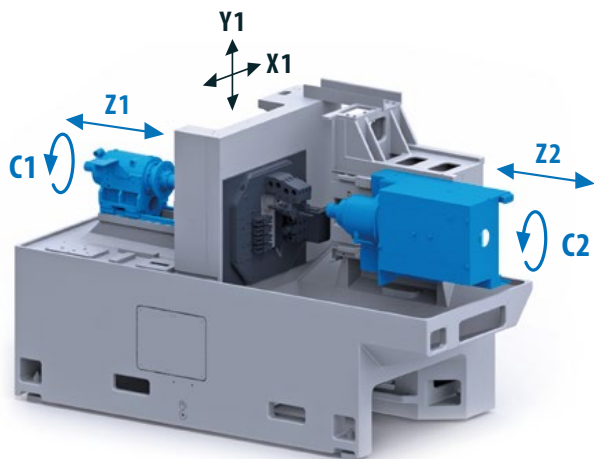

Specifications

Max. diameter of bar stock \varnothing	32 (36)
Spindle bore \varnothing	37
Spindle power kW 100%/25% - main	5,5/7,5
Spindle power kW 100%/30min. - sub	3,7/5,5
Spindle max. speed rpm - main	10 000
Spindle max. speed rpm - sub	10 000
Spindle stroke mm	410
Number of CNC axes	4+2
Programming channels	2
Tools in cut at the same time max	2
Live tools power kW	2,3

THE MANURHIN K'MX 432 is designed for productive machining of parts for bars with a maximum diameter of 32 mm. With a spindle bore diameter of 37 mm, no modification of the end of the bar for the bar feeder collet is needed. The machine comes standard with two electro spindles, each with a maximum speed of 10,000 rpm and with a rotary guide bush, synchronized by pulleys and belts from the main spindle. Four linear axes (X1, Y1, Z1, Z2), two rotary axes (C1, C2). **The machine is very strong when milling, with torque up to 32Nm!**



K'MX 532TREND

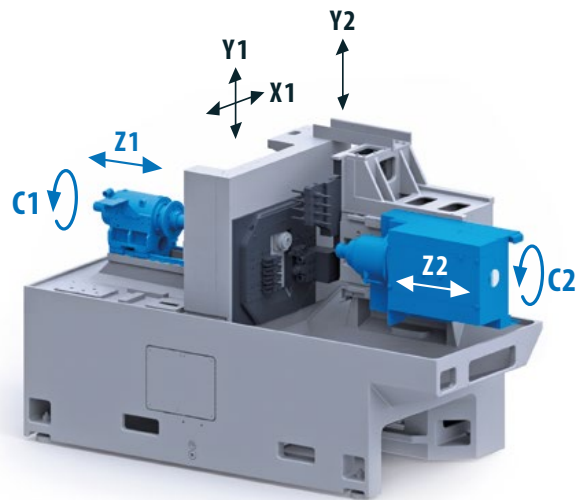
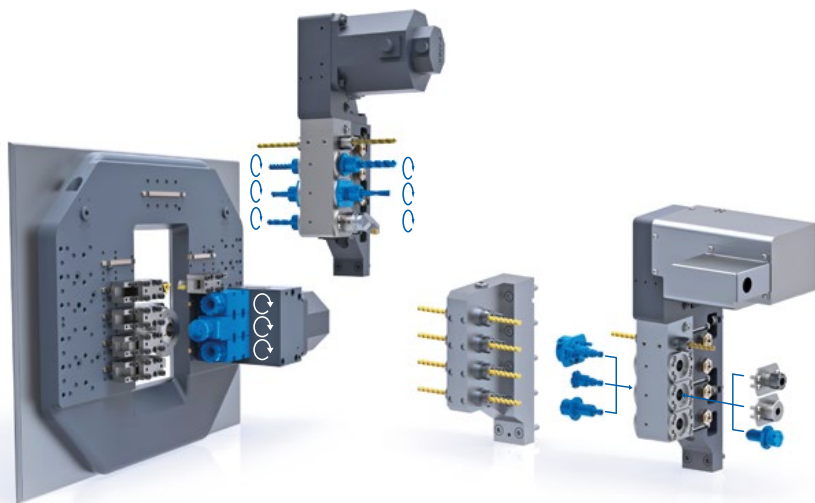

THE MANURHIN K'MX 532 TREND is designed for productive machining of parts for bars with a maximum diameter of 32 mm. With a spindle bore diameter of 37 mm, no modification of the end of the bar for bar feeder collet is needed. The machine comes standard with two electro spindles, each with a maximum speed of 10,000 rpm and with a rotary guide bush, synchronized by pulleys and belts from the main spindle. Five linear axes (X1, Y1, Y2, Z1, Z2) two rotary axes (C1, C2).

The machine is very strong when milling, with torque up to 32Nm!

Specifications

Max. diameter of bar stock Ø	32 (36)
Spindle bore Ø	37
Spindle power kW 100%/25% - main	5,5/7,5
Spindle power kW 100%/30min. - sub	3,7/5,5
Spindle max. speed rpm - main	10 000
Spindle max. speed rpm - sub	10 000
Spindle stroke mm	410
Number of CNC axes	5+2
Programming channels	2
Tools in cut at the same time max	2
Live tools power kW	2,3

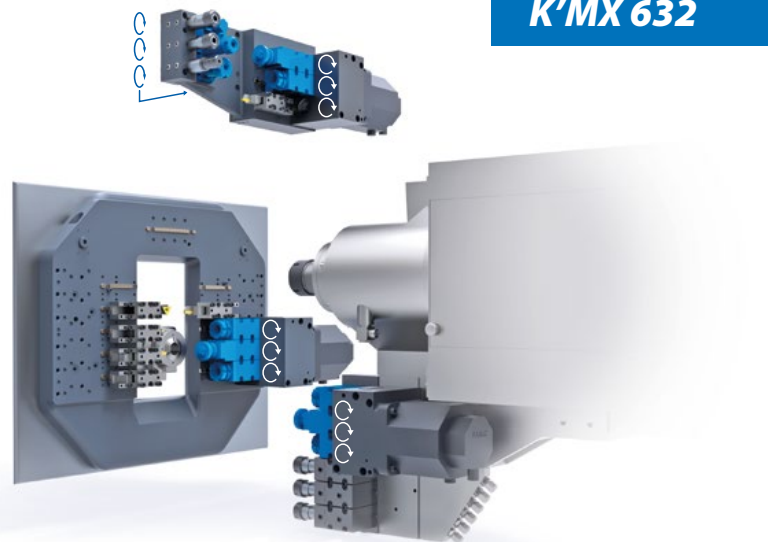
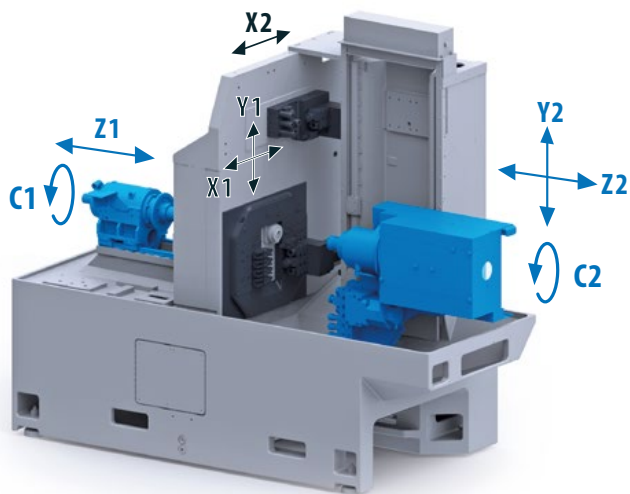

Specifications

Max. diameter of bar stock \varnothing	32 (36)
Spindle bore \varnothing	37
Spindle power kW 100%/25% - main	5,5/7,5
Spindle power kW 100%/30min. - sub	3,7/5,5
Spindle max. speed rpm - main	10 000
Spindle max. speed rpm - sub	10 000
Spindle stroke mm	410
Number of CNC axes	6+2
Programming channels	2
Tools in cut at the same time max	2
Live tools power kW	2,3

THE MANURHIN K'MX 632 is designed for productive machining of parts for bars with a maximum diameter of 32 mm. With a spindle bore diameter of 37 mm, no modification of the end of the bar for bar feeder collet is needed. The machine comes standard with two electro spindles, each with a maximum speed of 10,000 rpm and with a rotary guide bush, synchronized by pulleys and belts from the main spindle. Six linear axes (X1, X2, Y1, Y2, Z1, Z2), two rotary axes (C1, C2).

The machine is very strong when milling, with torque up to 32Nm!



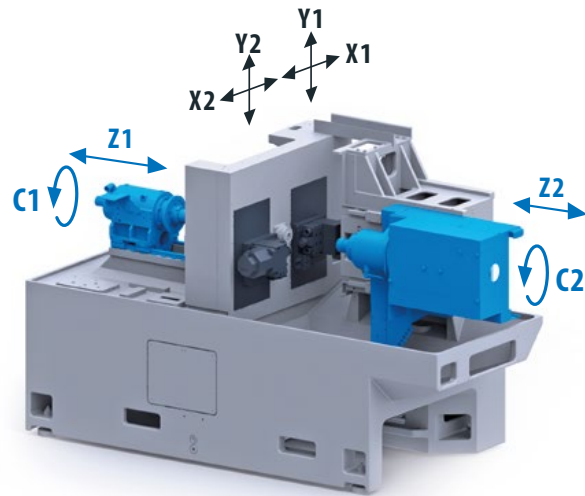
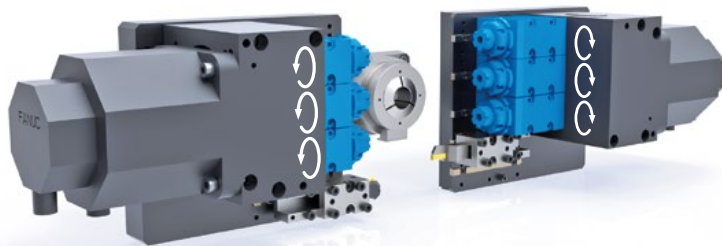

THE MANURHIN K'MX 632 DUO is designed for productive machining of parts for bars with a maximum diameter of 32 mm. With a spindle bore diameter of 37 mm, no modification of the end of the bar for bar feeder collet is needed. The machine comes standard with two electro spindles, each with a maximum speed of 10,000 rpm and with a rotary guide bush synchronized by pulleys and belts from the main spindle. Six linear CNC axes (X1, X2, Y1, Y2, Z1, Z2) and two rotary axes (C1, C2).

The machine is very strong when milling, with torque up to 32Nm! Another big advantage of this model is possibility of parallel turning or milling with two tools at the same time.

Specifications

Max. diameter of bar stock \varnothing	32 (36)
Spindle bore \varnothing	37
Spindle power kW 100%/25% - main	5,5/7,5
Spindle power kW 100%/30min. - sub	3,7/5,5
Spindle max. speed rpm - main	10 000
Spindle max. speed rpm - sub	10 000
Spindle stroke mm	410
Number of CNC axes	6+2
Programming channels	2
Tools in cut at the same time max	2
Live tools power kW	2,3

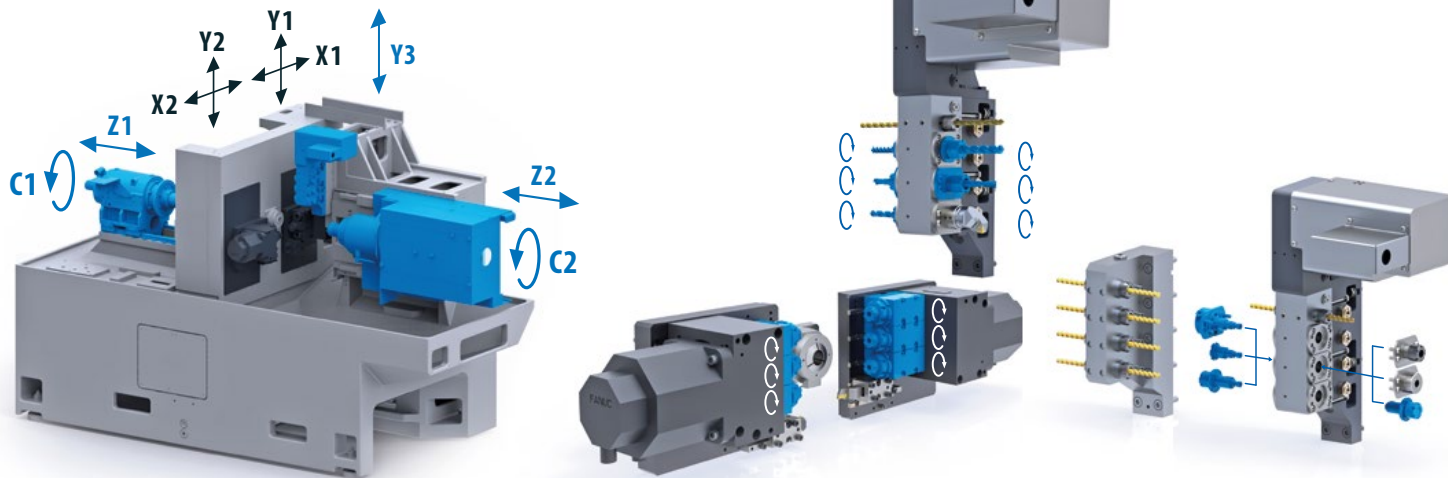

Specifications

Max. diameter of bar stock \varnothing	32 (36)
Spindle bore \varnothing	37
Spindle power kW 100%/25% - main	15/25
Spindle power kW 100%/30min. - sub	3,7/5,5
Spindle max. speed rpm - main	8 000
Spindle max. speed rpm - sub	10 000
Spindle stroke mm	410
Number of CNC axes	7+2
Programming channels	2
Tools in cut at the same time max	3
Live tools power kW	2,3

THE MANURHIN K'MX 732 EVO is designed for productive machining of parts for bars with a maximum diameter of 32 mm. The machine comes standard with two electro spindles and with a rotary guide bush synchronized by pulleys and belts from the main spindle. Seven linear CNC axes (X1, X2, Y1, Y2, Y3, Z1, Z2) and two rotary axes (C1, C2) enable the machine to produce parts ranging from very simple to extremely complex. **The construction solution and very strong spindle motor enables the use of up to 3 tools at the same time. The machine is very strong when milling, with torque up to 32Nm!**



K'MX 816 CLEVER

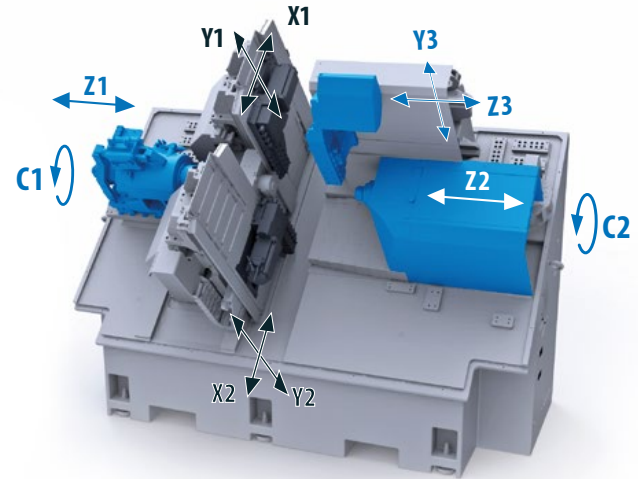
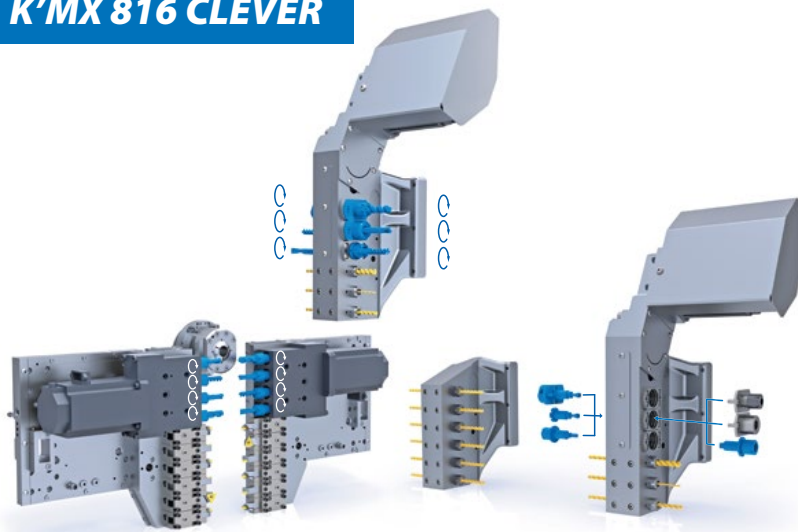

THE MANURHIN K'MX 816 CLEVER is designed for the productive machining of parts for bars of a maximum diameter of either 16mm or 20mm. The machine comes standard with two electro spindles and a rotary guide bush that is synchronized by pulleys and belts from the main spindle. Eight linear CNC axes (X1, X2, Y1, Y2, Y3, Z1, Z2, Z3) and two rotary axes (C1, C2) enable the machine to produce parts ranging in complexity. **The construction solution enables the use of 4 tools at the same time.**

Specifications

Max. diameter of bar stock \emptyset	16 (20)
Spindle bore \emptyset	21 (23)
Spindle power kW 100%/30min. - main	3,7/5,5
Spindle power kW 100%/30min. - sub	3,7/5,5
Spindle max. speed rpm - main	12 000
Spindle max. speed rpm - sub	12 000
Spindle stroke Z1 mm	220
Number of CNC axes	8+2
Programming channels	3
Tools in cut at the same time max	4
Live tools power kW	1

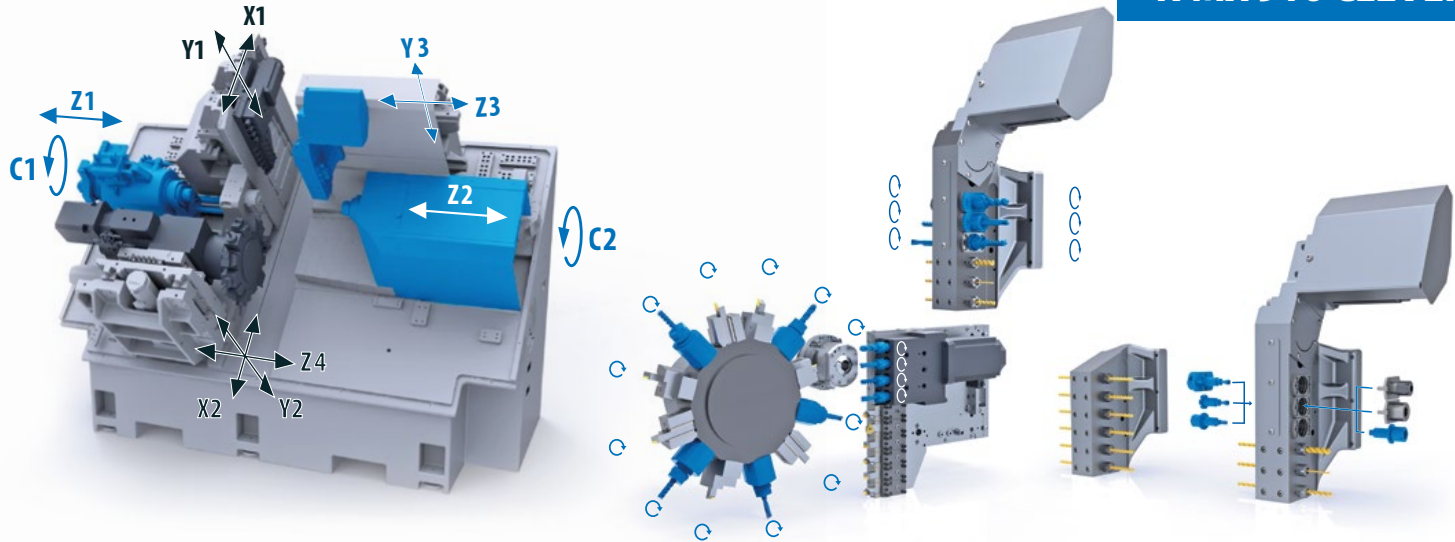

Specifications

Max. diameter of bar stock Ø	16 (20)
Spindle bore Ø	21 (23)
Spindle power kW 100%/30min. - main	3,7/5,5
Spindle power kW 100%/30min. - sub	3,7/5,5
Spindle max. speed rpm - main	12 000
Spindle max. speed rpm - sub	12 000
Spindle stroke Z1 mm	220
Turret stroke Z4 mm	65
Number of CNC axes	9+2
Programming channels	4
Tools in cut at the same time max	4
Live tools power kW	2,3

THE MANURHIN K'MX 916 CLEVER is designed for the productive machining of parts for bars with a maximum diameter of either 16mm or 20mm. The machine comes standard with two electro spindles and with a rotary guide bush that is synchronized by pulleys and belts from the main spindle. **12 positions tool turret Baruffaldi for VDI 20 tools** enables with Z4 axis to do two different turning operations at one time on the main spindle. Nine linear CNC axes (X1, X2, Y1, Y2, Y3, Z1, Z2, Z3, Z4) and two rotary axes (C1, C2) enables the use of 4 tools at the same time.



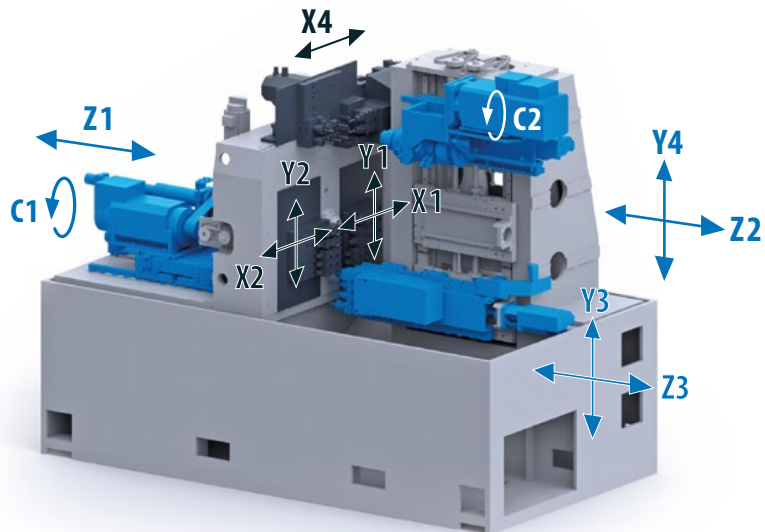
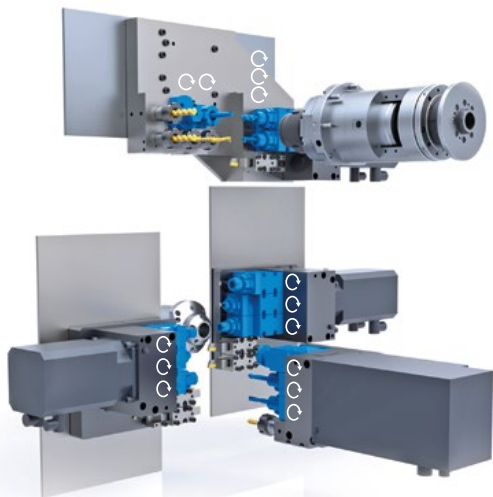

THE MANURHIN K'MX SWING is delivered in two versions – one for bars \varnothing 26 and one for bars \varnothing 32 mm (bar preparation is needed). The highlight of the K'MX SWING is the productivity. Up to 23 tools (including 14 powered tools) can be working simultaneously with 10 independent axes. Tool changes are quick and easy with the compatible tool holder cartridge system. Programming is simple with the K'MX PLUS software. The large door opening provides easy access while the control works under MS WINDOWS. **Ten linear CNC axes (X1, X2, X4, Y1, Y2, Y3, Y4, Z1, Z2, Z3) and two rotary axes (C1, C2) enables the use of 4 tools at the same time.**

Specifications

Max. diameter of bar stock \varnothing	26 (32)
Spindle bore \varnothing	33
Spindle power kW 100%/60% - main	5,5/7,5
Spindle power kW 100%/60% - sub	3,7/5,5
Spindle max. speed rpm - main	8 000
Spindle max. speed rpm - sub	8 000
Spindle stroke mm	250
Number of CNC axes	10+2
Programming channels	3
Tools in cut at the same time max	4
Live tools power kW	2,3





MANURHIN|KMX[®]

TAJMAC-ZPS, a. s. | třída 3. května 1180 | 763 02 Zlín, Malenovice | CZECH REPUBLIC
Tel.: +420 577 532 072 | Fax: +420 577 533 626 | www.tajmac-zps.cz | e-mail: info@tajmac-zps.cz